



OakGate EPIC-128C0S

128-Slot SATA / SAS SSD Tester

Key Features

Industry-leading temperature range

- -5° C to +90° C

Supports up to 128 SFF card type SSDs

- SFF(Single Port / Dual Port) & M.2 supported with attachments

Comprehensive functionality

- Long-run testing
- Aging test
- Low and high temperature testing
- Marginal voltage testing

High-performance R/W access on thermal and marginal voltage test

Discharge circuit can shorten voltage turn-off time and stabilize power cycle test

No PCIe bridge chip used, resulting in stable software performance

Test engine mounted outside, not affected by chamber temperature

Stable, high-speed serial communication from PC to the device

Adjustable airflow ranging from 700 to 1500 LFM to each SSD

- Various air speeds can be adjusted to accommodate end-user's requirements

Intuitive GUI

OakGate is partnered with Daichu Technologies to provide a broad series of versatile and high-performance turnkey testers that enable customers to exercise the power of the OakGate software in reliability and manufacturing environments for NVMe, SAS, and SATA SSDs. These Epic Testers are powered by OakGate's Greenlight Manufacturing Test Application and Storage Validation Framework (SVF) software, the storage industry's most advanced testing software.

The OakGate EPIC-128C0S is a high-performance thermal chamber designed for the comprehensive testing of up to 128 SFF type SSDs simultaneously. By generating an industry-leading temperature range of -5°C to +90°C, and by providing an adjustable airflow of 700-1500 LFM to each SSD, this chamber is capable of simulating a broad range of environmental conditions.

The EPIC-128C0S unit is controlled by Teledyne LeCroy's OakGate SVF software, which interfaces to OakGate appliances, as well as to several popular SSD production testers, such as the OakGate Epic Testers.

Teledyne LeCroy's OakGate SVF software offers a comprehensive list of features that enable users to:

- Generate traffic and inject errors
- Measure performance (IOPS, bandwidth, latency)
- Control power and temperature
- Execute customized test sequences
- Test devices at full-performance
- Exercise built-in protocol conformance test suite and analyzer

Robust GUI

Greenlight is the advanced manufacturing test software that brings the power of the OakGate test platform to the world of manufacturing through an innovative, efficient, powerful, and easy-to-use test application for storage devices under test (DUTs), such as solid state drives (SSDs).

Greenlight runs on top of OakGate's Storage Validation Framework (SVF) engine, the most advanced storage testing software, allowing the DUTs to be fully evaluated and verified. The SVF interfaces to OakGate appliances, as well as to several popular SSD production testers, such as the OakGate Epic Testers.

Designed from the beginning to be simple to use, yet advanced in its capabilities – the user interface is ideal for the production floor, as well as for development and field failure analysis.

- User interface designed for ease of use
- Optimized views for operators and engineers
- Test-board-centric views, where the interface directly reflects the physical test board layout, helping operators maintain accuracy when populating, testing and removing good/failed boards from the system

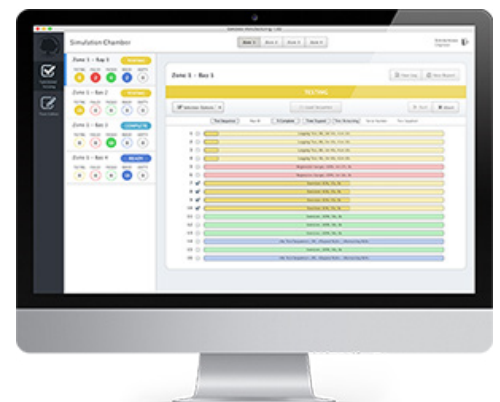

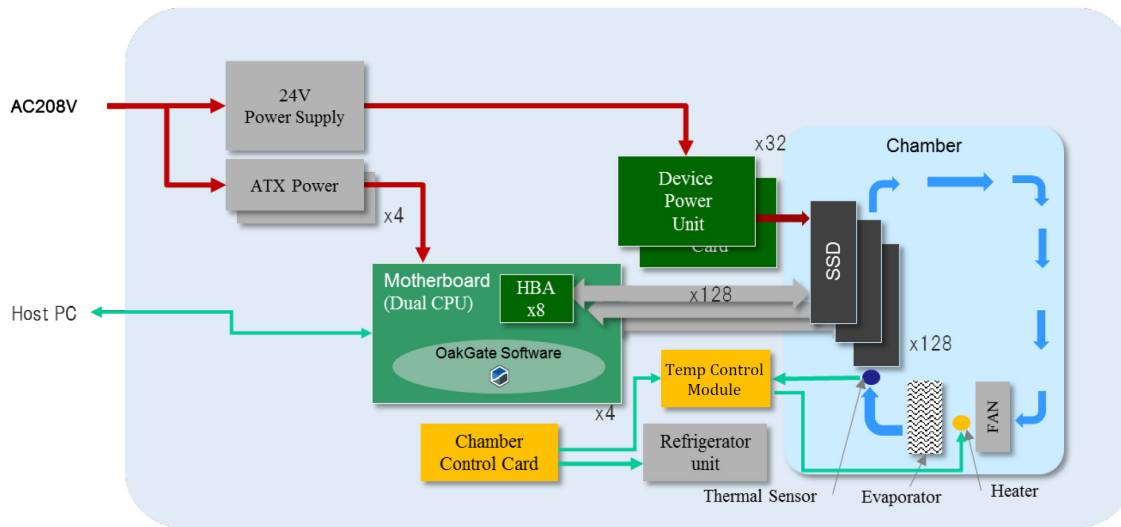

Specifications

Supported SSD Specifications	Form Factor: SATA 2.5 inch / SAS SFF type IF Spec: SATA 3.0 / SAS 12G Number of Slots: 128 Device Power Supply: 50W / Total 6,400W
Chamber Specifications	Set Temperature: -5 to +90 degC (30w/slot); 0 to+90 degC (50w/slot) Airflow (Blow speed): Approx. 700 ~ 1500 LFM (Adjustable) Door Lock: Locked less than 20° C / more than 45° C
SSD Power Supply	3.3V: 2.0A (Typ.) 3.0A (Peak) 12V: 2.0A (Typ.) 3.0A (Peak) Voltage Margin: ±15% Voltage Slope: 0 to 100msec : Variable in each (3.3V / 5V, 12V) Discharge Time: Free or less than 200msec (SSD Capacity < 500uF)
Test Engine	Software: Supported by OakGate (SVF) Motherboard: Dual CPU ATX (XEON E5) Number of Test Engine: 4pcs PCIe Slots: LSI SAS 9300-8i SGL 8pcs installed
Other Functions	LED Indicator: Power status (Power, SSD insertion); Test status (Idle, Run, Pass, Fail) Host PC IF: Ethernet (RJ45)
Input Requirements	AC voltage(Hz) / Current: AC 208V (50/60Hz) / Max 100A Dry Air: 6 m3/hrs. [0.5 ~ 1.0 MPa]
Mechanical	Dimensions: Approx. 1,500mm (W) x 1,480mm (D) x 2,050mm (H) Weight: Approx. 1,300kg

* Environmental Temperature : 22-28°C

Ordering Information

Product Description

Epic 128-Slot SAS/SATA SSD Tester -5 to +90°C

Product Code

OGT-EPIC-128C0S



Local sales offices are located throughout the world.
Visit our website to find the most convenient location.

1-800-5-LeCroy • teledynelecroy.com



TELEDYNE LECROY
Everywhereyoulook™